

Desing Standard	API 6D / ISO 14313
End Type	ASME B 16.5

- * Split Body
- * Flange End
- * Above Ground
- * Flotting or Trunnion Ball
- * Double Block and Bleed
- * Fire Safety
- * Anti Static Device
- * Anti Blowout
- * Soft Seat

GENERAL TOLERANCE	
TS 1845-1 / EN 20286-1	
0-10	= ±0,05
0-20	= ±0,10
20-50	= ±0,20
50-100	= ±0,25
100-200	= ±0,30
200-500	= ±0,50

 MAKINA SANAYII VE TICARET A.Ş.	Prepared By	Furkan DAYI	Publication Date	05.03.2020	Materials
	Draw By	Furkan DAYI	Revision No		Reference No
	Checking	Tayfun TOYGA	Revision Date		Product No
	Approval	Burak TÜREMEN	General Tol.		Piece No
Customer	Scale	Product	DN 150 CLASS 600 BKV FLTG		
		Piece			

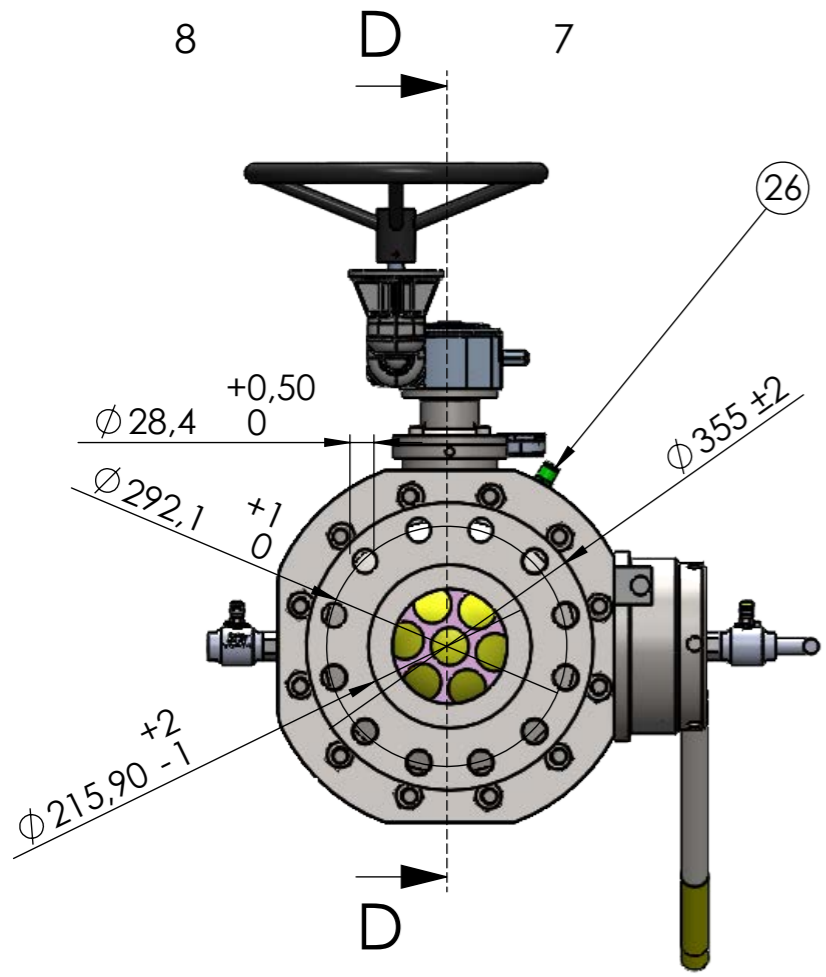

MATERIAL DATA

ITEM NO	ITEM DESCRIPTION	MATERIAL
28	BALL SUPPORT BEAR	
27	BALL SUPPORT	
26	GREASE INJECTOR	
25	GEARBOX	ROTORK
24	ADAPTOR SPINDLE	4140 - 5140
23	ADAPTOR	ASTM A 105
22	BAFFLE	ASTM A 105
21	NUT	1.4301.
20	STUD	1.4301.
19	COUNTER NUT	1.4301.
18	BOWL WASHER	1.4301.
17	PRESSURE RING	1.4301. - 1.4401.
16	SPINDLE O-RING	VİTON
15	BURGMAN GRAPHITE O-RING	EN 1514-1
14	NECK TIGHTNESS ELEMENT	PTFE-Teflon
13	NECK O-RING	VİTON
12	NECK TIGHTNESS ELEMENT	PTFE-Teflon
11	NECK	ASTM A 105
10	SPRING	1.4301.
9	SEAT RING O-RING	VİTON
8	COVER O-RING	VİTON
7	BODY O-RING	VİTON
6	BALL TIGHTNESS ELEMENT	PTFE-Teflon
5	SEAT RING	ASTM A 105
4	ACTION SPINDLE	SS 316
3	BALL	SS 316
2	COVER	ASTM A 105
1	BODY	ASTM A 105

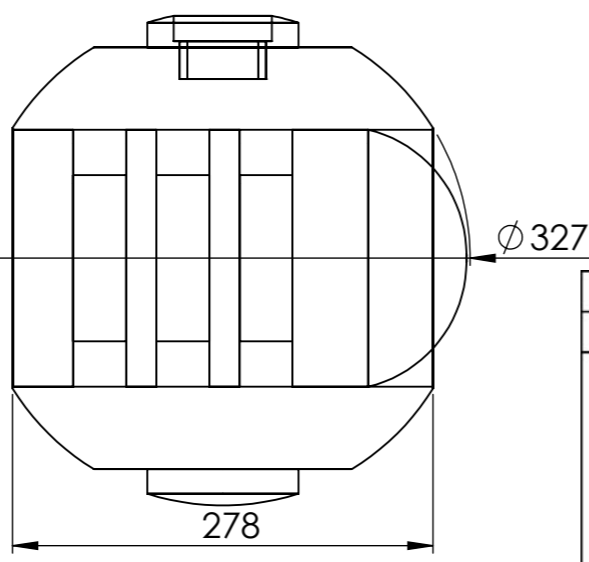
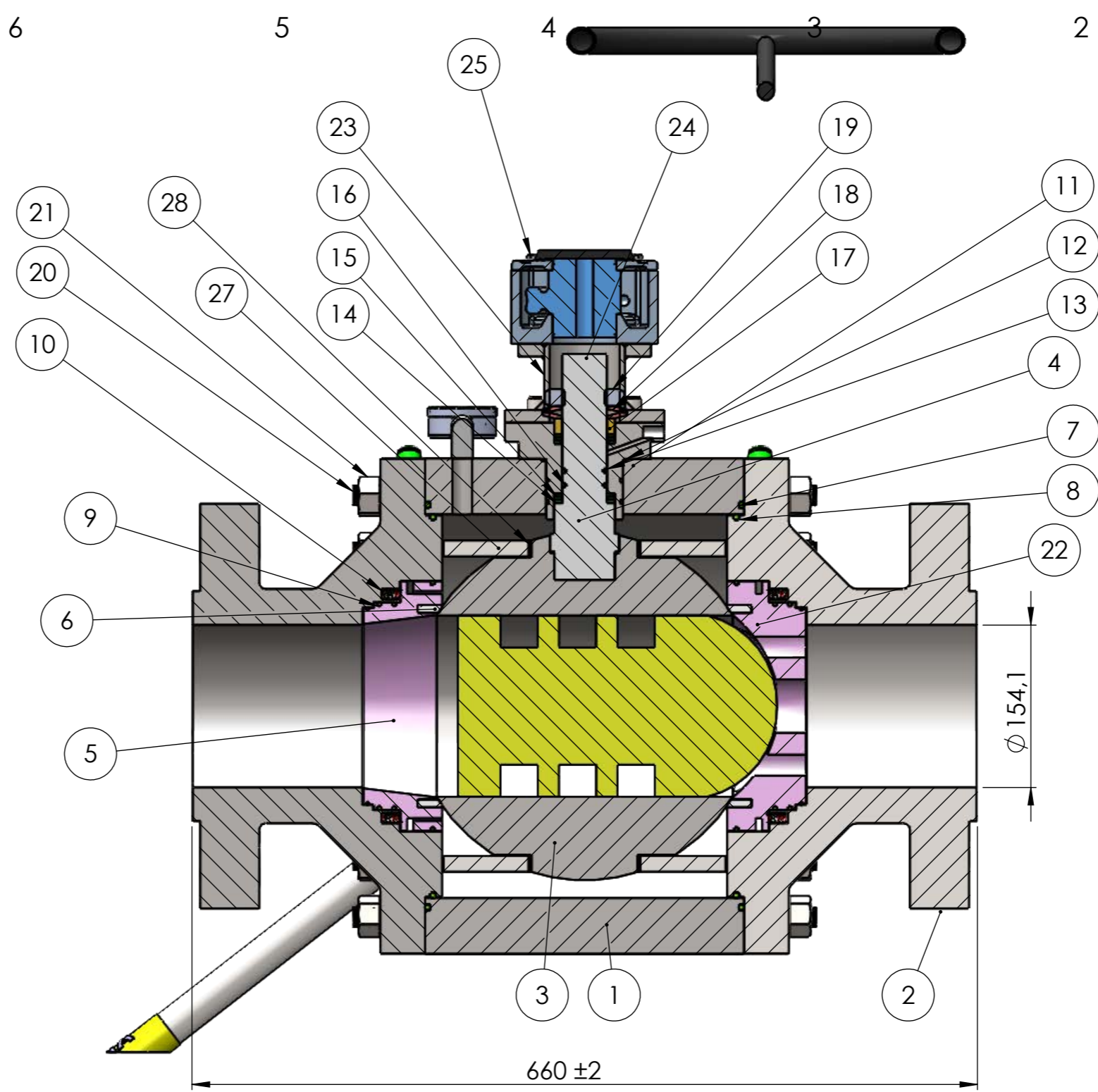

GENERAL TOLERANCE	
TS 1845-1 / EN 20286-1	
0-10	= ±0,05
0-20	= ±0,10
20-50	= ±0,20
50-100	= ±0,25
100-200	= ±0,30
200-500	= ±0,50

- * Split Body
- * Flange End
- * Above Ground
- * Flotting or Trunnion Ball
- * Double Block and Bleed
- * Fire Safety
- * Anti Static Device
- * Anti Blowout
- * Soft Seat

Desing Standard	API 6D / ISO 14313
End Type	ASME B 16.5

 <small>MAKINA SANAYII VE TICARET A.Ş.</small>	Prepared By	Furkan DAYI	Publication Date	05.03.2020	Materials
	Draw By	Furkan DAYI	Revision No		Reference No
<small>Customer</small>	Checking	Tayfun TOYGA	Revision Date		Product No
	Approval	Burak TÜREMEN	General Tol.		Piece No
Scale	Product	DN 150 CLASS 600 BKV FLTG			
	Piece				

8 7 6 5 4 3 2 1

F
E
D
C
B
A

F
E
D
C
B
A

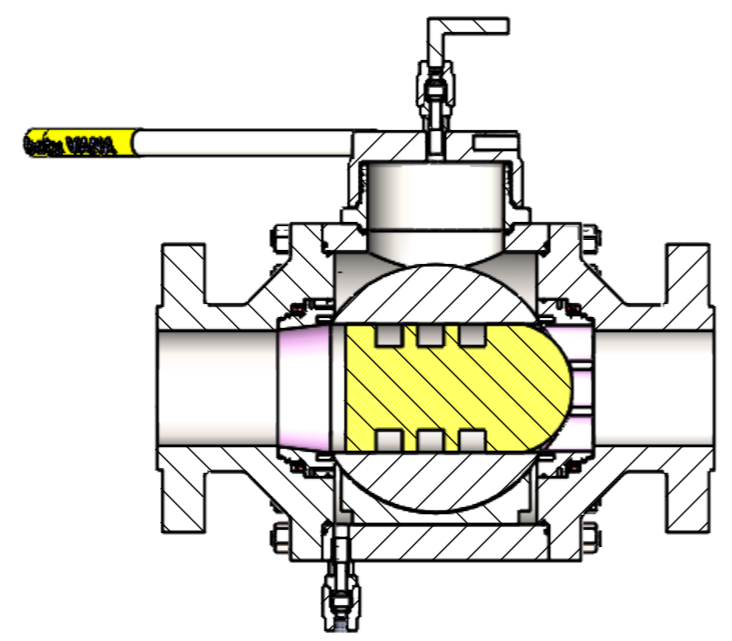
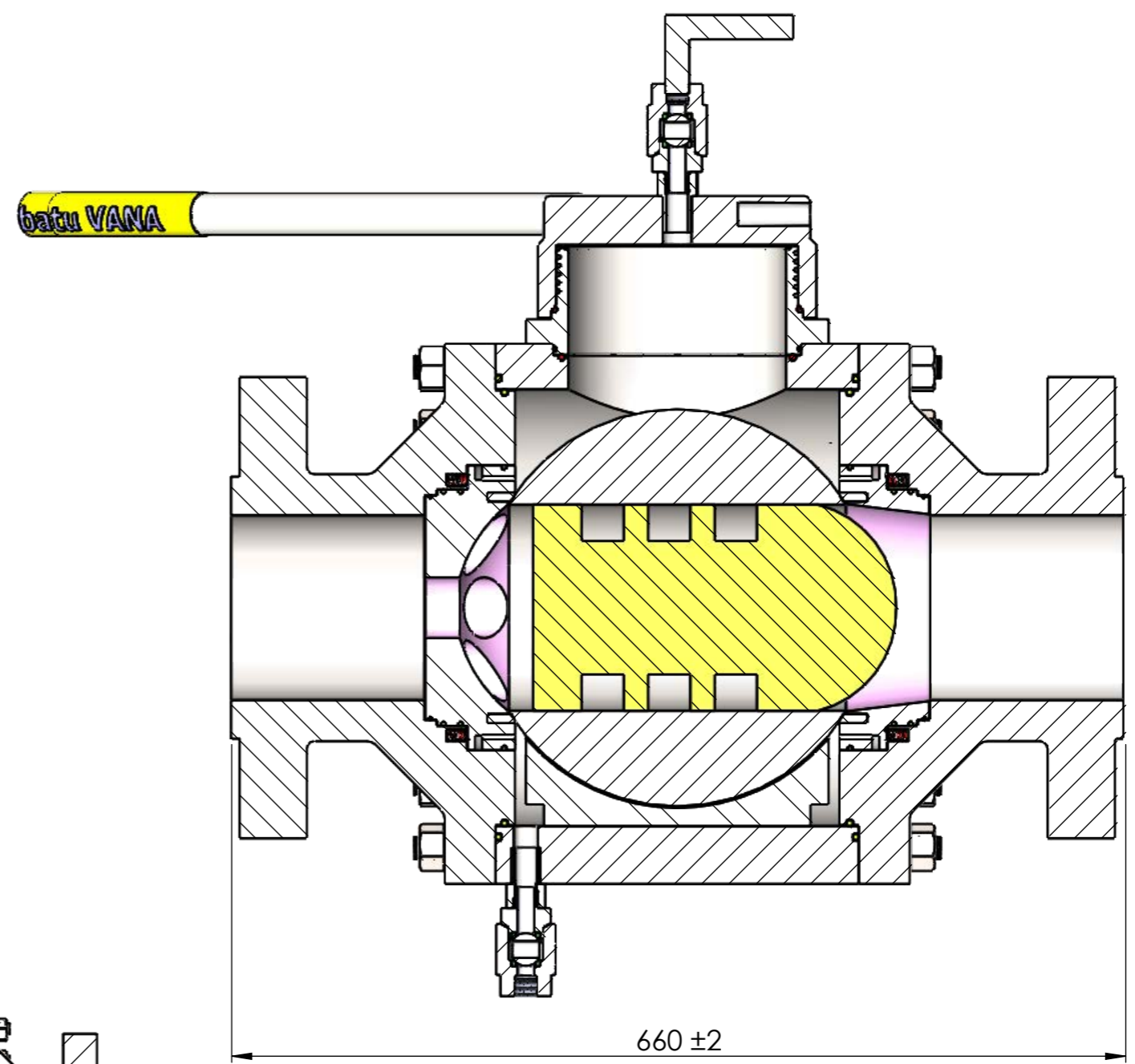
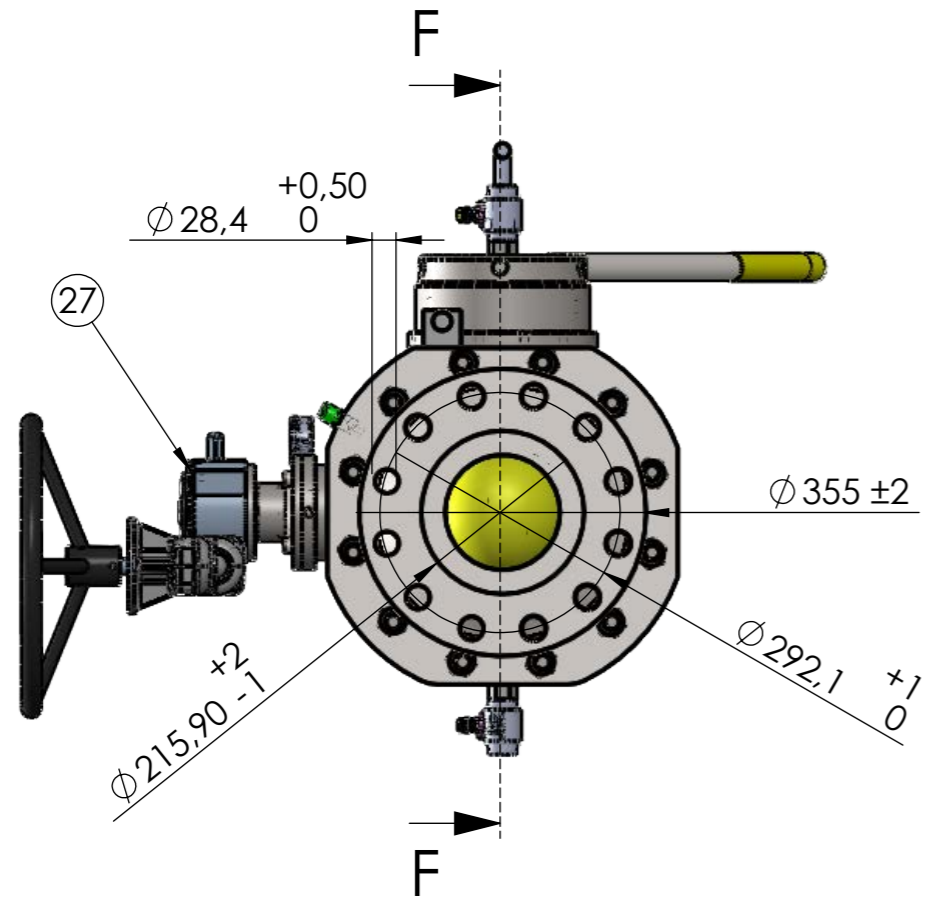

Desing Standard	API 6D / ISO 14313
End Type	ASME B 16.5

- * Split Body
- * Flange End
- * Above Ground
- * Flotting or Trunnion Ball
- * Double Block and Bleed
- * Fire Safety
- * Anti Static Device
- * Anti Blowout
- * Soft Seat

GENERAL TOLERANCE	
TS 1845-1 / EN 20286-1	
0-10	= ±0,05
0-20	= ±0,10
20-50	= ±0,20
50-100	= ±0,25
100-200	= ±0,30
200-500	= ±0,50

 MAKINA SANAYII VE TICARET A.Ş.	Prepared By	Furkan DAYI	Publication Date	05.03.2020	Materials
	Draw By	Furkan DAYI	Revision No		Reference No
Customer	Checking	Tayfun TOYGA	Revision Date		Product No
	Approval	Burak TÜREMEN	General Tol.		Piece No
	Scale	Product	DN 150 CLASS 600 BKV FLTG		
		Piece			

www.batusan.com

8 7 6 5 4 3 2 1