

TİP TYPE BKV-FL-RG	DN 15 - DN 200	PN 25	SFERO DÖKÜM SPHERO	REDÜKSİYON GEÇİŞLİ / FLANŞLI FULL BORE / FLANGED
-----------------------	----------------	-------	-----------------------	---

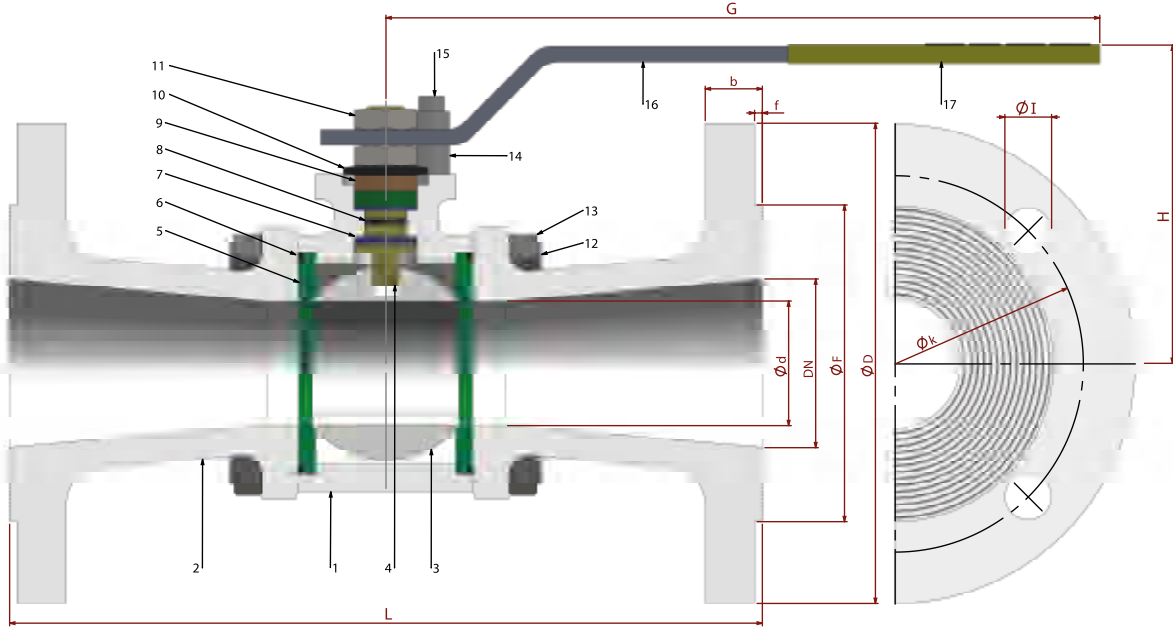

PARÇA NO ITEM NO	PARÇA ADI ITEM DISCRPTION	MALZEME MATERIAL
17	PLASTİK KAPLAMA PLASTIC COVERING	PVC
16	KÜRE HAREKET KOLU BALL ACTION HANDLE	st 37
15	CİVATA BOLT	ST 42 Gal.
14	STOPLAMA PİMİ STOPPING PIM	ST 42 Gal.
13	SOMUN NUT	5.6.
12	SAPLAMA STOPPING PIM	CK 35 / CK 45
11	KONTRA SOMUN COUNTER NUT	5,6 Gal.
10	ÇANAK PUL BOWL WASHER	50 Cr V 4
9	BASKI RİNGİ PRESSURE RING	MS 58
8	MİL O-RİNG SPINDLE O-RING	VİTON
7	BOĞAZ SIZDIRMAZLIK TEFLONU NECK TIGHTNESS ELEMENT	PTFE-Teflon
6	GÖVDE O-RİNG BODY O-RING	VİTON
5	KÜRE SIZDIRMAZLIK TEFLONU BALL TIGHTNESS ELEMENT	PTFE-Teflon
4	HAREKET MİLİ ACTION SPINDLE	1,4021
3	KÜRE BALL	1.4301 / 1.4086
2	KAPAK COVER	GGG 40.3
1	GÖVDE BODY	GGG 40.3

Boyut	Dimensions	: TS 3148 / EN 558
Bağlantılar	Connections	: EN 1092-2
Çalışma Basıncı	Working Pressure	: PN 25
Çalışma Sıcaklığı	Working Temperature	: -20 °C / +180 °C

Kullanım Alanları Usege Areas :
 Su, Sıcak Su, Buhar, Basıncılı Hava
 Water, Hot Water, Steam, Pressurized Air

BOYUT ve BAĞLANTI ÖLÇÜLERİ DIMENSIONS AND CONNECTION SIZES

		PN 16											
		L	G	H	f	d	D	b	k	Hole Unit	I	F	Kg
DN 15	1/2"	130	150	75	2	12	95	16	65	4	14	45	2,3
DN 20	3/4"	150	150	83	2	15	105	18	75	4	14	58	3,4
DN 25	1"	160	150	83	2	20	115	18	85	4	14	68	5,6
DN 32	1 1/4"	180	180	90	2	25	140	20	100	4	19	78	7,2
DN 40	1 1/2"	200	230	95	3	32	150	20	110	4	19	88	10
DN 50	2"	230	275	115	3	40	165	22	125	4	19	102	14,6
DN 65	2 1/2"	290	275	120	3	50	185	24	145	4	19	122	20,7
DN 80	3"	310	320	135	3	65	200	24	160	8	19	138	30,8
DN 100	4"	350	380	150	3	80	235	24	190	8	23	162	48
DN 125	5"	400	450	170	3	100	270	26	220	8	28	188	78,7
DN 150	6"	450	450	200	3	125	300	28	250	8	28	218	--
DN 200	8"	550	650	235	3	150	360	30	310	12	28	278	--